



**XB6- PC80B**

**Pulse Counting Module**

**user manual**



Nanjing Solidot Electronic Technology Co., Ltd.

**All rights reserved © Nanjing Solidot Electronic Technology Co.**

Without the written permission of the Company, any unit or individual may not extract or copy part or all of the contents of this document without permission, and may not be disseminated in any form.

**Trade Mark Statement**

 and other Solidot trademarks are trademarks of Nanjing Solidot Electronic Technology Co.

All other trademarks or registered trademarks mentioned in this document are owned by their respective owners.

**Take note of**

Your purchase of products, services or features, etc. is subject to the commercial contracts and terms and conditions of Salient, and all or some of the products, services or features described in this document may be excluded from your purchase or use. Unless otherwise agreed in the contract, Solidot makes no representations or warranties, express or implied, with respect to the contents of this document.

The contents of this document may be updated from time to time due to product version upgrades or other reasons. Unless otherwise agreed, this document is intended as a guide to use only, and all statements, information and recommendations in this document do not constitute any warranty, express or implied.

Nanjing Solidot Electronic Technology Co.

Address: 11/F, Angying Mansion, No. 91 Shengli Road, Jiangning District, Nanjing, Jiangsu Province, P.R. China

Postcode: 211106

Tel: 4007788929

Website: <http://www.solidotech.com>

# CONTENTS

1	Product Overview.....	1
1.1	Product Description.....	1
1.2	Product Characteristics.....	1
2	Product Parameters.....	2
2.1	General Parameters.....	2
3	Panels.....	3
3.1	Module structure.....	3
3.2	Indicator light function.....	4
4	Mounting and dismounting.....	5
4.1	External Dimensions.....	5
4.2	Installation Guide.....	5
4.3	Mounting and dismounting procedure.....	7
4.4	Installation Diagram.....	7
5	Wiring.....	11
5.1	Wiring diagram.....	11
5.2	Terminal block definition.....	12
6	Use.....	13
6.1	Process data.....	13
6.1.1	Uplink data.....	13
6.1.2	Downlink data.....	14
6.2	Module Configuration Description.....	15
6.2.1	Application in the TwinCAT3 software environment.....	15
6.2.2	Application in the TIA Portal V17 software environment.....	22

# 1 Product Overview

---

## 1.1 Products

XB6-PC80B is a plug-in pulse counting module, which adopts X-bus bottom bus and is suitable for XB6 series coupler module of our company. The module has 8 pulse counting channels, which can sample and analyse pulse signals with a frequency of 600Hz or less, derive the frequency and pulse count value of each channel, and support single channel counting zero.

## 1.2 Product Characteristics

- Eight-channel pulse counting  
Eight channels can monitor pulse frequency and pulse count values completely independently.
- Supports pulse count clearing  
The data of the eight pulse counting channels can be cleared independently.
- Pulse counting frequency  
Supports pulse frequencies up to 600Hz.
- Small volume  
Compact and small footprint.
- Easy diagnosis  
Innovative channel indicator design, close to the channel, at a glance, easy to detect and maintain.
- Easy configuration  
Simple configuration, supports mainstream PROFINET masters and EtherCAT masters.
- Easy installation  
DIN 35 mm standard rail mounting  
Adopts bullet type terminals for easy and quick wiring.

# 2 Product Parameter

## 2.1 Common parameter

<b>Interface parameter</b>	
Product Model	XB6-PC80B
Bus protocol	X-bus
Process data volume: uplink	48 Bytes
Process data volume: downstream	1 Byte
Channel Type	Pulse input channels: 8 channels, PNP
Refresh rate	1 ms
<b>Technical parameters</b>	
System Input Power	5VDC
Field-side power supply rating (range)	24VDC (18V~36V)
Input Channel Voltage Ratings (Range)	24VDC (15V~30V)
Pulse input frequency range	0~600Hz
Pulse Input Meter Value Range	0~2 <sup>32</sup> -1
Overall dimensions	106 x 73 x 25.7mm
Weights	90g
Wiring Method	Screw less Quick Plugs
Operating temperature	-10°C~+60°C
Storage temperature	-20°C~+75°C
Relative humidity	95%, non-condensing
Protection class	IP20

# 3 Kneading board

## 3.1 Module structure

**Name of each part of the product**

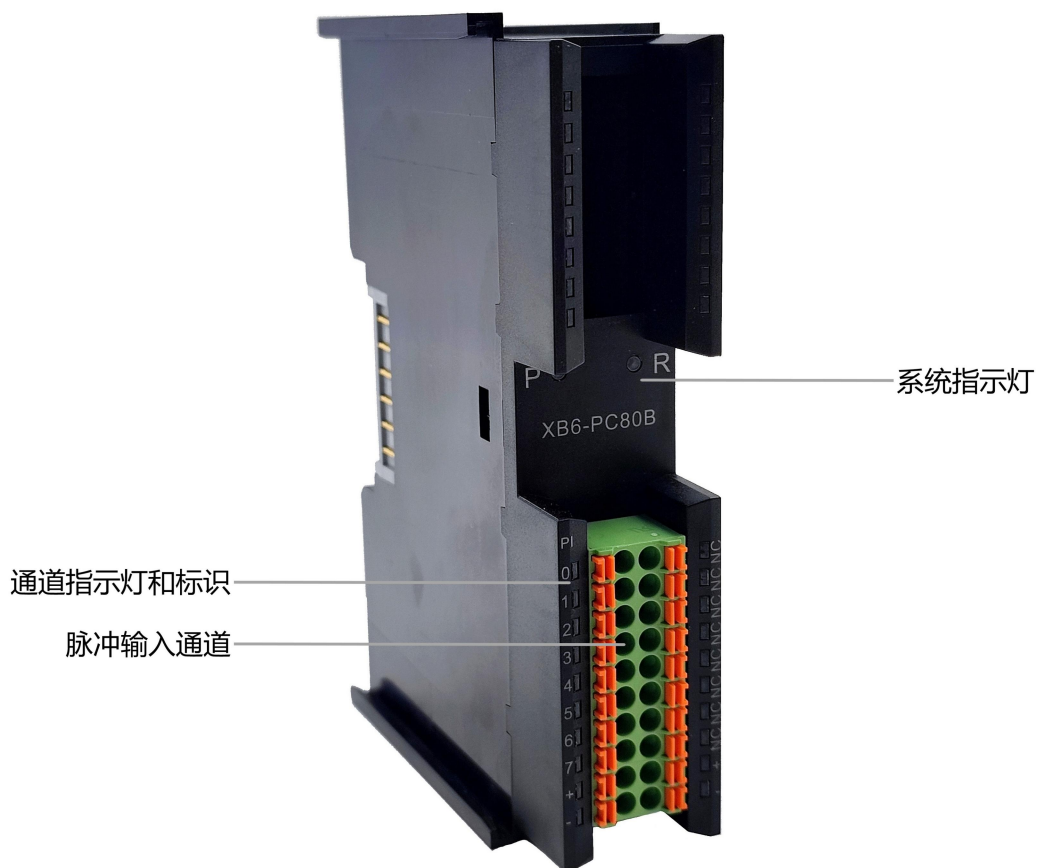

## 3.2 Indicator light function

Name	Markings	Colour	State of affairs	State Description
Power indicator	P	Green	ever-bright	Power supply normal
			go out (of fire)	The product is not powered up or the power supply is abnormal
Communication Indicator Light	R	Green	ever-bright	The system is functioning normally
			Flashing 1Hz	Module connected, X-bus system ready for interaction
			go out (of fire)	Device is not powered up, X-bus is not interacting with data or is abnormal
Pulse input channel indicator	0~7	Green	ever-bright	Channels have signal inputs
			go out (of fire)	No signal input on channel

# 4 Installation and dismantling

## 4.1 Overall dimensions

### Outline specification (unit mm)

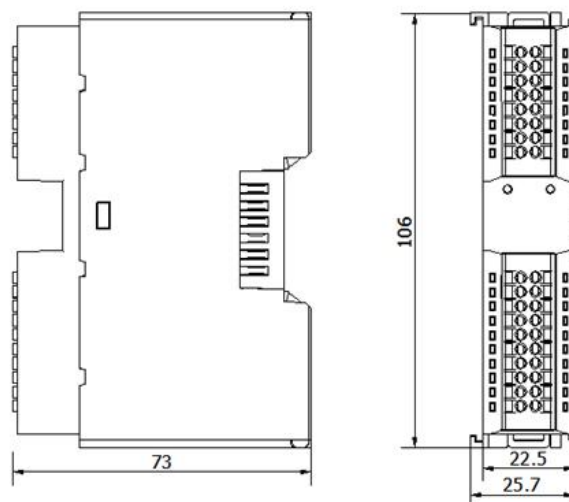

## 4.2 Installation Guide

### Precautions for installation\dismantling

- Ensure that the cabinet is well ventilated (e.g., the cabinet is fitted with an exhaust fan).
- Do not install the unit next to or above equipment that may cause overheating.
- Be sure to install the module vertically and maintain air circulation around it (at least 50 mm air circulation space above and below the module).
- Once the module is installed, be sure to secure the module by installing rail mounts on both ends.

- Be sure to disconnect the power supply when installing/disassembling.

**Minimum clearance for module mounting ( $\geq 50\text{mm}$ )**

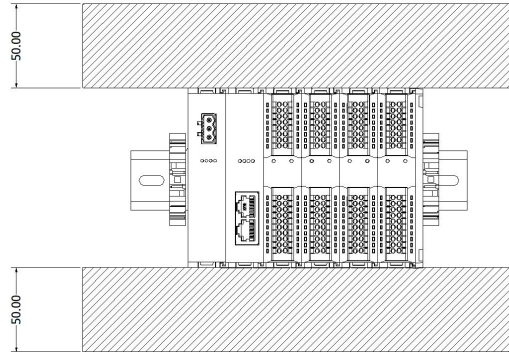

**Ensure that the module is mounted vertically**

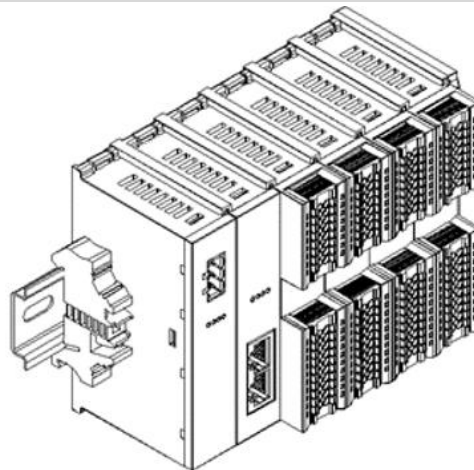

**Be sure to install the rail fixings**

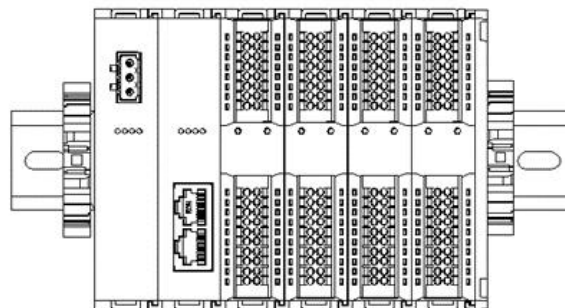

### 4.3 Installation and dismantling steps

Module Installation and Removal	
Module Installation Procedure	1. Install the power supply module on the fixed rail first.
	2. Install the coupler and the required I/O modules in turn to the right of the power supply module.
	3. After installing all required I/O modules, install the end caps to complete the module assembly.
	4. Install the rail fixings at both ends of the power module and end cap to fix the module.
Module disassembly procedure	1. Loosen the rail fixings at both ends of the module.
	2. Use a one screwdriver to pry off the module snap.
	3. Pull out the disassembled module.

### 4.4 Installation Diagram

#### Power Module Installation

move

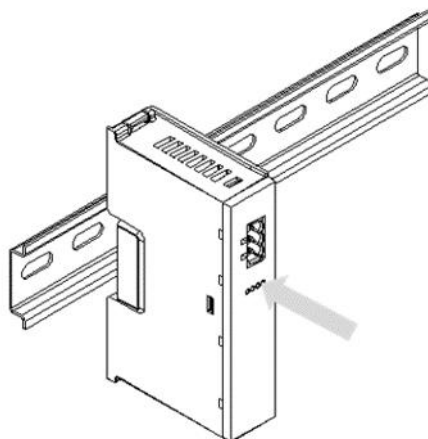

Align the power module rail slots, as shown in Figure ① on the left, vertically to the rails.

①

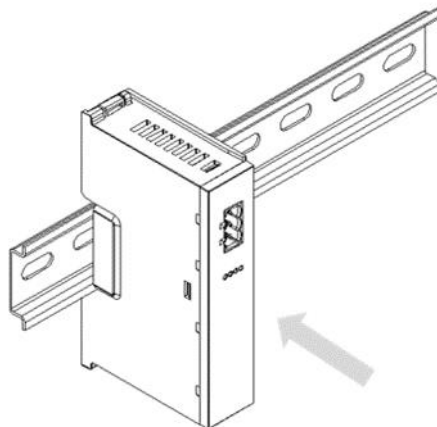

As shown in Figure 2 on the left, press the power module firmly, and the module will be installed in place when you hear a "click" sound.

②

### Coupler Module Installation

move

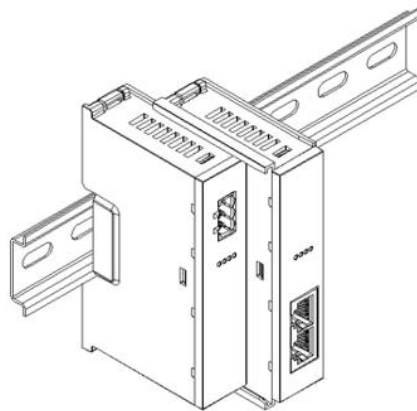

Align the left slot of the coupler module with the right side of the power supply module and push it in as shown in figure ③ on the left. Press the coupler module firmly and the module will click into place.

(iii)

### I/O Module Installation

move

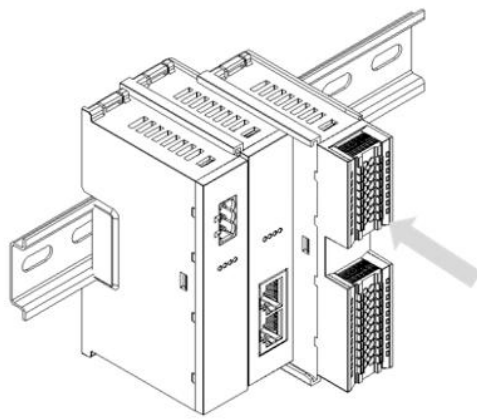

④

Install the required I/O modules one by one as shown in Figures ④ and ⑤ on the left, following the procedure of installing the coupler module in the previous step.

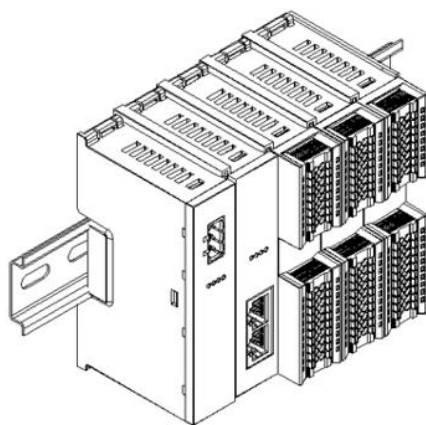

⑤

**End cap retrofit**

**move**

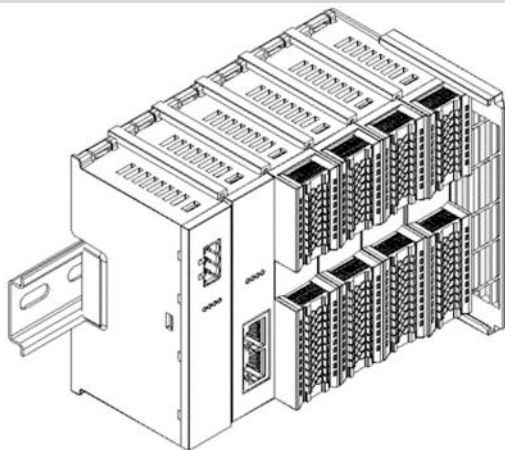

(vi)

Install the end cap on the right side of the last module as shown in Figure 6 on the left, and refer to the installation method of the coupler module.

**Retrofitting of guide rail fixings**

**move**

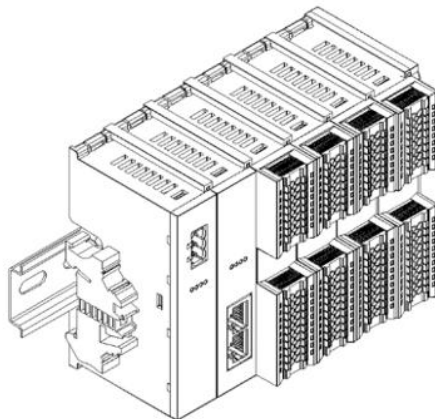

(vii)

Install and lock the rail retainer firmly against the left side face of the coupler as shown in Figure 7 on the left.

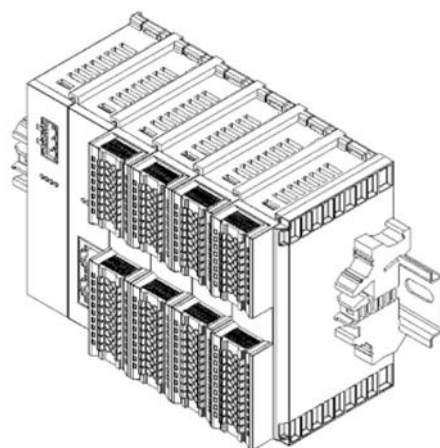

Install the rail fixing on the right side of the end cap, first push the rail fixing firmly in the direction of the coupler to ensure that the module is mounted tightly, and lock the rail fixing with a screwdriver, as shown in Figure 8 on the left.

⑧

**dismantle**

**move**

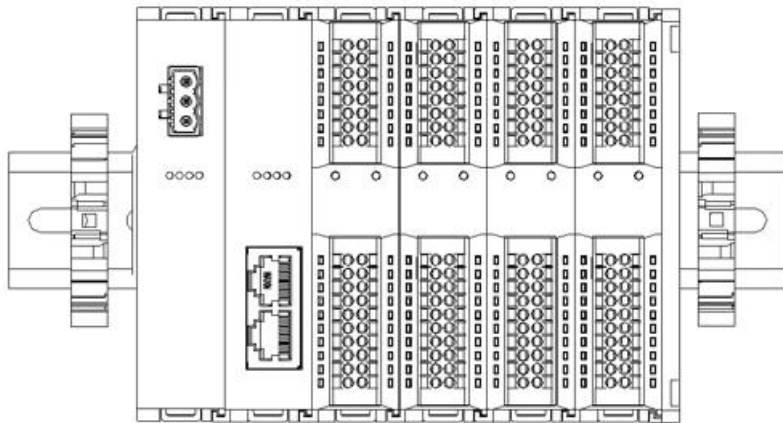

Loosen the rail fixing at one end of the module with a screwdriver and move it to one side, making sure that there is a gap between the module and the rail fixing, as shown in Figure 9 on the left.

⑨

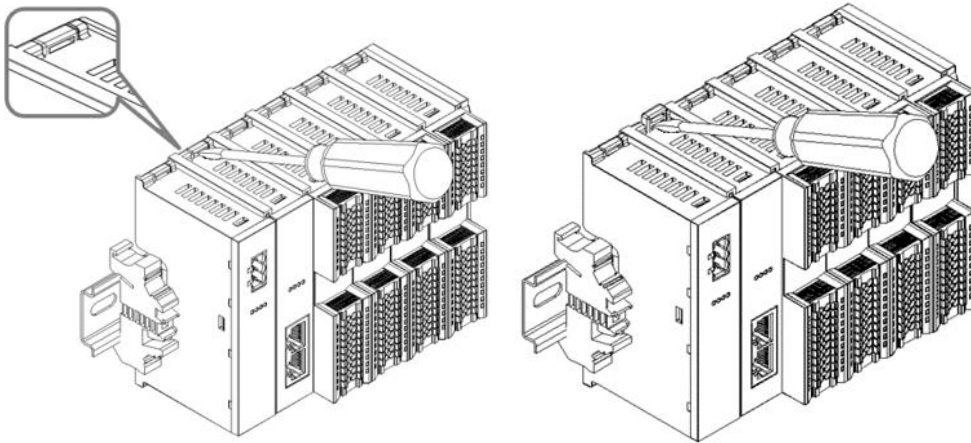

Insert a flat head screwdriver into the snap of the module to be removed and apply force (hear a rattle) in the direction of the module sideways, as shown in Figures ⑩ and ⑪ on the left.

**Note: Each module has one snap at the top and bottom, all operate in this way.**

⑪ ⑩

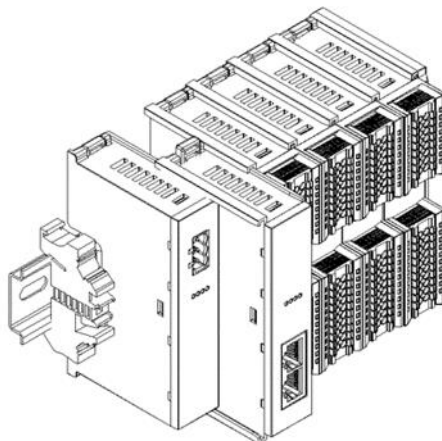

Remove the module as shown in Figure ⑫ on the left, following the reverse operation of installing the module.

⑫

# 5 Connect and wiring

## 5.1 Wiring diagram

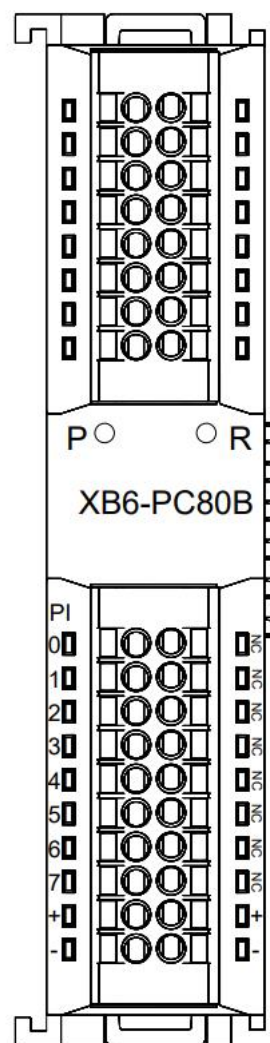
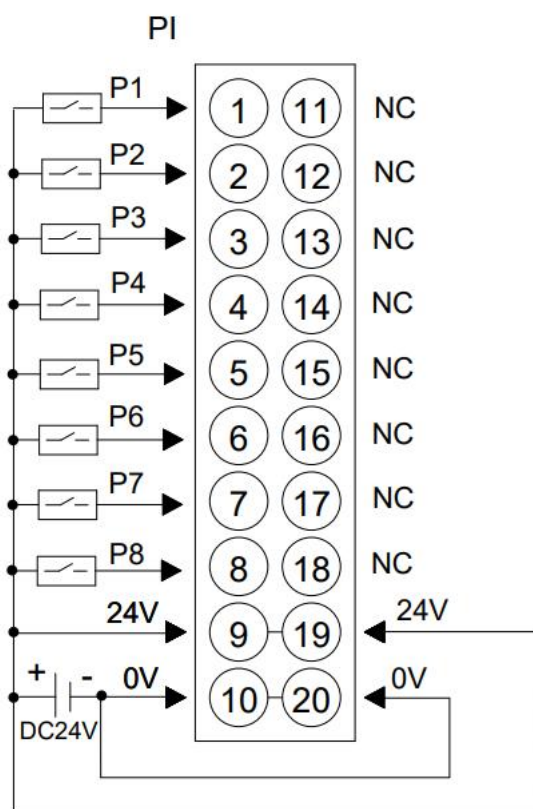

- For personal and equipment safety, it is recommended that the power supply be disconnected during wiring operations.

## 5.2 Terminal Block Definition

PI			/		
Terminal Serial Number	Terminal identification	Instructions	Terminal Serial Number	Terminal identification	Instructions
1	0	Pulse input channel 1	11	NC	empty terminal
2	1	Pulse input channel 2	12	NC	empty terminal
3	2	Pulse input channel 3	13	NC	empty terminal
4	3	Pulse input channel 4	14	NC	empty terminal
5	4	Pulse input channel 5	15	NC	empty terminal
6	5	Pulse input channel 6	16	NC	empty terminal
7	6	Pulse input channel 7	17	NC	empty terminal
8	7	Pulse input channel 8	18	NC	empty terminal
9	+	Power+	19	+	Power+
10	-	Power supply -	20	-	Power supply -

# 6 Usage

## 6.1 Process data

### 6.1.1 Uplink data

48 bytes of uplink data (6 bytes per channel, channel [n] takes values 1 to 8)				
Name	Meaning	Range of values	Data type	Lengths
Channel [n] Frequency	Pulse Input Frequency	0~600 (unit: Hz)	UINT	2 bytes
Channel [n] Count value	Pulse input count value	0 to $2^{32}-1$ (unit: one)	UDINT	4 bytes

#### Data description:

◆ **Pulse Input Frequency Channel [n] Frequency**

When the pulse input channel has pulse input, the pulse frequency can be sampled and analysed; when there is no pulse input, the frequency is 0. If the channel clear signal is 0, the frequency is displayed normally, and the frequency data is cleared to zero when the clear signal is set to "1".

◆ **Pulse input count value Channel [n] Count value**

The pulse count value can be sampled and analysed when a pulse is input to the pulse input channel. If the channel zero signal is set to 0, the pulse count value is continuously accumulated; when the zero signal is set to 1, the pulse count value data is cleared to zero.

## 6.1.2 Downlink data

Downstream command 1 byte (channel [n] takes values 1~8)					
Name	Meaning	Range of values	Data type	Lengths	Address
Channel [n] Clear value	Pulse data clear enable	0: Frequency and count values are displayed normally	bool	1bit	bit0~bit7
		1: Zeroing of frequency and count data			

### Data description:

#### ◆ Pulse data clear enable Channel [n] Clear value

When the pulse data clear enable of a pulse input channel is set to "1", the count value of the channel will be cleared to zero and no longer accumulate, and the frequency will be displayed as 0; when the channel clear enable is set to "0", the count value of the pulse and the frequency will be resumed to be displayed normally.

**Note:** *Pulse data clear enable needs to be reset to 0 after setting it to 1 before pulse counting can be performed.*

## 6.2 Module Configuration Description

### 6.2.1 Application in TwinCAT3 software environment

#### 1、Preliminary

- **Hardware environment**

- **Module Model XB6-PC80B**

- **Power Module, EtherCAT Coupler, End cover**

This description takes the XB6-P2000H power supply, XB6-EC0002 coupler as an example

- **A computer with pre-installed TwinCAT3 software**

- **Shielded cables for EtherCAT**

This description takes the connection of the XB6-P04A module as an example.

- **One switch power supply**

- **Module mounting rails and rail fixings**

- **Device Configuration File**

Configuration file access: <https://www.solidotech.com/documents/configfile>

- **Hardware configuration and wiring**

Follow "[4 Mounting and dismounting](#)" and "[5 Wiring](#)".

#### 2、Preset Profiles

Place the ESI configuration file (EcatTerminal-XB6\_V3.13\_ENUM.xml) in the TwinCAT installation directory under "C:\TwinCAT\3.1\Config\Io\EtherCAT" as shown below.

名称	修改日期	类型	大小
Beckhoff EQ1xxx.xml	2015/11/12 14:24	XML 文档	22 KB
Beckhoff EQ2xxx.xml	2016/11/23 10:42	XML 文档	73 KB
Beckhoff EQ3xxx.xml	2016/11/22 11:22	XML 文档	1,386 KB
Beckhoff ER1xxx.XML	2016/11/21 15:46	XML 文档	165 KB
Beckhoff ER2xxx.XML	2016/11/21 14:32	XML 文档	259 KB
Beckhoff ER3xxx.XML	2017/6/9 13:35	XML 文档	1,177 KB
Beckhoff ER4xxx.xml	2016/11/22 12:58	XML 文档	318 KB
Beckhoff ER5xxx.xml	2016/3/14 11:52	XML 文档	273 KB
Beckhoff ER6xxx.xml	2016/3/14 11:52	XML 文档	494 KB
Beckhoff ER7xxx.xml	2016/11/22 12:14	XML 文档	1,503 KB
Beckhoff ER8xxx.xml	2016/3/14 11:52	XML 文档	207 KB
Beckhoff EtherCAT EvaBoard.xml	2015/2/4 12:57	XML 文档	72 KB
Beckhoff EtherCAT Terminals.xml	2015/2/4 12:57	XML 文档	53 KB
Beckhoff FB1XXX.xml	2017/5/24 12:26	XML 文档	49 KB
Beckhoff FCxxxx.xml	2015/2/4 12:57	XML 文档	21 KB
Beckhoff ILxxx-B110.xml	2015/2/4 12:57	XML 文档	8 KB
EcatTerminal-XB6_V3.13_ENUM.xml	2023/5/24 10:12	XML 文档	493 KB

### 3. Create Project

- a. Click the TwinCAT icon in the lower right corner of the desktop and select "TwinCAT XAE (VS xxxx)" to open the TwinCAT software as shown below.



- b. Click "New TwinCAT Project", in the pop-up window, "Name" and "Solution name" correspond to the project name and solution name respectively. In the pop-up window, "Name" and "Solution name" correspond to the project name and solution name respectively, and "Location" corresponds to the project path, you can choose the default for these three items, and then click "OK", the project is created successfully, as shown in the following figure.

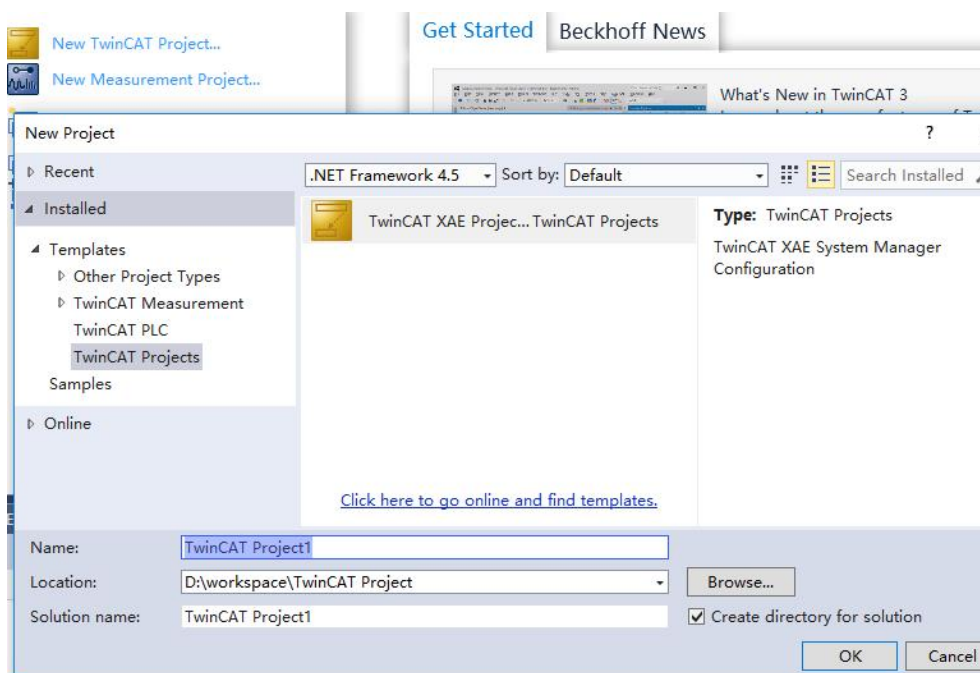

## 4. Scanning device

- a. After creating the project, right-click on the "Scan" option under "I/O -> Devices" to perform a slave device scan, as shown in the following figure.

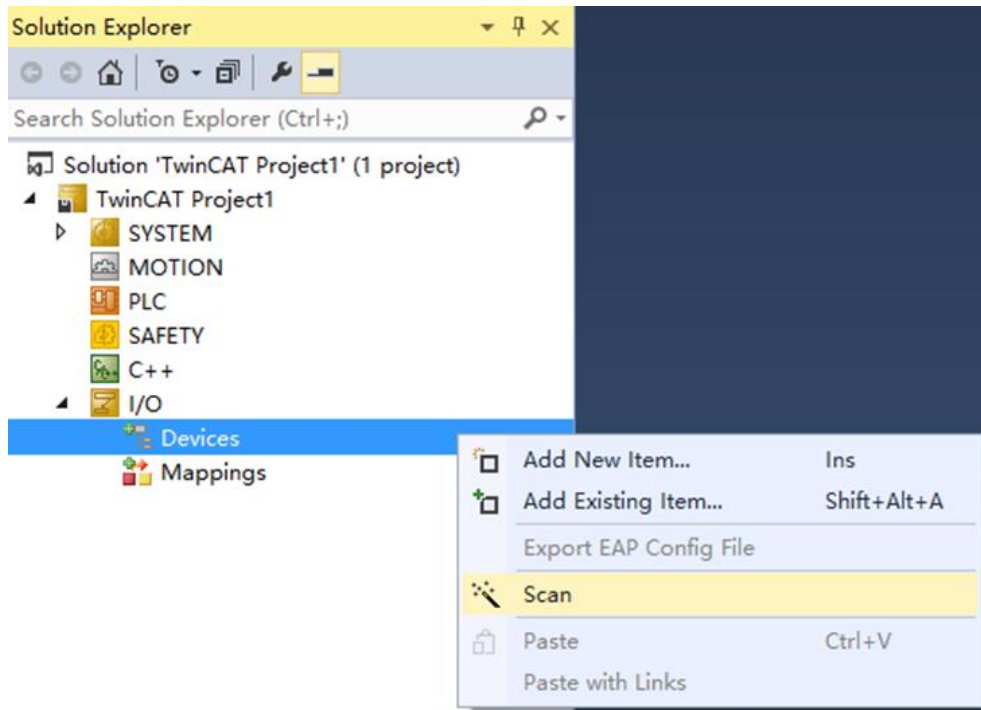

- b. Tick the "Local Connections" tab as shown below.



- c. Click on the pop-up window "Scan for boxes" and select "Yes"; click on the pop-up window "Activate Free Run" and select "Yes", as shown in the figure below. "Yes", as shown in the figure below.



- d. After scanning to the device, you can see Box1 (XB6-EC0002) and Module1 (XB6-PC80B) and Module2 (XB6-P04A) in the left navigation tree, and at "Online" you can see TwinCAT in the "OP" state, and you can observe that the RUN light of the slave device is always on. At "Online", you can see TwinCAT is in "OP" state, and you can observe that the RUN lamp of the slave device is always on, as shown in the figure below.

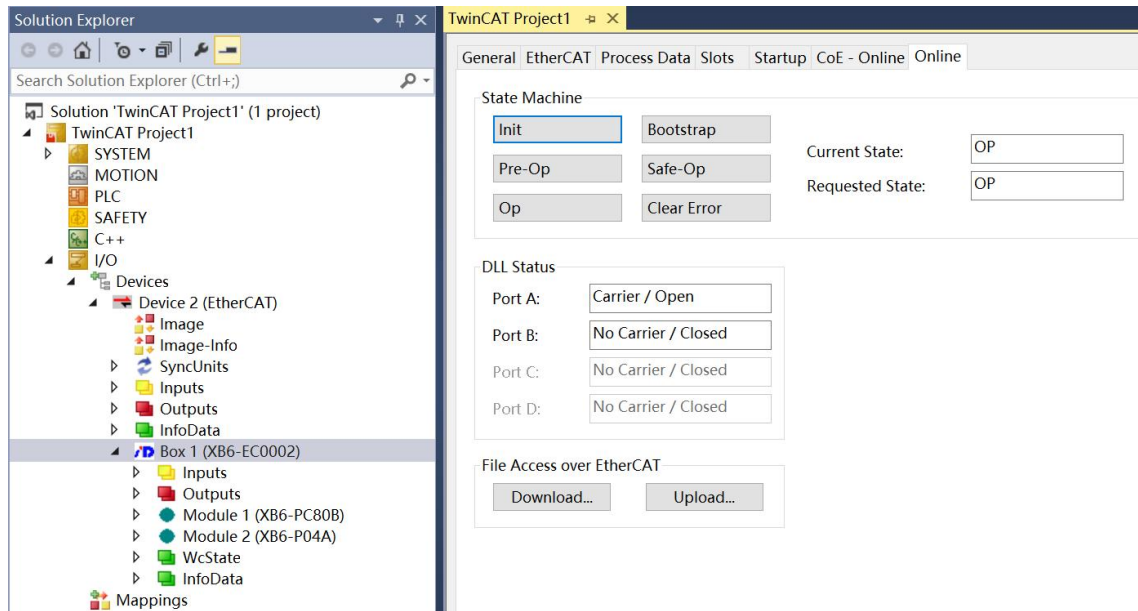

### 5. Verify Basic Functions

- a. The left navigation tree "Module 1 -> Inputs" displays the module's upstream data, which is used to monitor the module's pulse frequency and pulse count values, as shown in the figure below.

The screenshot shows the TwinCAT Project1 interface. On the left, the Solution Explorer tree is expanded to 'Module 1 (XB6-PC80B)' > 'Inputs'. On the right, a table displays the upstream data for these inputs.

Name	Online	Type	Size	>Address	In/Out	User ID	Linked to
Channel 1 frequency	0	UINT	2.0	41.0	Input	0	
Channel 1 count value	0	UDINT	4.0	43.0	Input	0	
Channel 2 frequency	0	UINT	2.0	47.0	Input	0	
Channel 2 count value	0	UDINT	4.0	49.0	Input	0	
Channel 3 frequency	0	UINT	2.0	53.0	Input	0	
Channel 3 count value	0	UDINT	4.0	55.0	Input	0	
Channel 4 frequency	0	UINT	2.0	59.0	Input	0	
Channel 4 count value	0	UDINT	4.0	61.0	Input	0	
Channel 5 frequency	0	UINT	2.0	65.0	Input	0	
Channel 5 count value	0	UDINT	4.0	67.0	Input	0	
Channel 6 frequency	0	UINT	2.0	71.0	Input	0	
Channel 6 count value	0	UDINT	4.0	73.0	Input	0	
Channel 7 frequency	0	UINT	2.0	77.0	Input	0	
Channel 7 count value	0	UDINT	4.0	79.0	Input	0	
Channel 8 frequency	0	UINT	2.0	83.0	Input	0	
Channel 8 count value	0	UDINT	4.0	85.0	Input	0	

- b. The left navigation tree "Module 1 -> Outputs" displays the downstream data of the module. It is used to control the zeroing of the pulse data of the module as shown in the following figure.

The screenshot shows the TwinCAT Project1 interface. On the left, the Solution Explorer tree is expanded to 'Module 1 (XB6-PC80B)' > 'Outputs'. On the right, a table displays the downstream data for these outputs.

Name	Online	Type	Size	>Address	In/Out	User ID	Linked to
Channel 1 clear value	0	BIT	0.1	41.0	Output	0	
Channel 2 clear value	0	BIT	0.1	41.1	Output	0	
Channel 3 clear value	0	BIT	0.1	41.2	Output	0	
Channel 4 clear value	0	BIT	0.1	41.3	Output	0	
Channel 5 clear value	0	BIT	0.1	41.4	Output	0	
Channel 6 clear value	0	BIT	0.1	41.5	Output	0	
Channel 7 clear value	0	BIT	0.1	41.6	Output	0	
Channel 8 clear value	0	BIT	0.1	41.7	Output	0	

### Examples of module functions

◆ **Pulse Input channel 1 data monitoring and clearing**

- a. When channel 1 inputs 50000 pulses with a frequency of 400Hz, the module's uplink data pulse frequency and pulse count value, as shown below. When the pulse starts to be sent, the pulse count value continues to accumulate, and the pulse frequency is monitored in real time. When sending is completed, the pulse count value accumulates to 50000; when there is no pulse input, the frequency is 0.

Name	Online	Type	Size	>Address	In/Out	User ID	Linked to
Channel 1 frequency	400	UINT	2.0	41.0	Input	0	
Channel 1 count value	50000	UDINT	4.0	43.0	Input	0	
Channel 2 frequency	0	UINT	2.0	47.0	Input	0	
Channel 2 count value	0	UDINT	4.0	49.0	Input	0	
Channel 3 frequency	0	UINT	2.0	53.0	Input	0	
Channel 3 count value	0	UDINT	4.0	55.0	Input	0	
Channel 4 frequency	0	UINT	2.0	59.0	Input	0	
Channel 4 count value	0	UDINT	4.0	61.0	Input	0	
Channel 5 frequency	0	UINT	2.0	65.0	Input	0	
Channel 5 count value	0	UDINT	4.0	67.0	Input	0	
Channel 6 frequency	0	UINT	2.0	71.0	Input	0	
Channel 6 count value	0	UDINT	4.0	73.0	Input	0	
Channel 7 frequency	0	UINT	2.0	77.0	Input	0	
Channel 7 count value	0	UDINT	4.0	79.0	Input	0	
Channel 8 frequency	0	UINT	2.0	83.0	Input	0	
Channel 8 count value	0	UDINT	4.0	85.0	Input	0	

- b. Pulse input channel 1 count clear enable as shown below.

Name	Online	Type	Size	>Address	In/Out	User ID	Linked to
Channel 1 clear value	1	BIT	0.1	41.0	Output	0	
Channel 2 clear value	0	BIT	0.1	41.1	Output	0	
Channel 3 clear value	0	BIT	0.1	41.2	Output	0	
Channel 4 clear value	0	BIT	0.1	41.3	Output	0	
Channel 5 clear value	0	BIT	0.1	41.4	Output	0	
Channel 6 clear value	0	BIT	0.1	41.5	Output	0	
Channel 7 clear value	0	BIT	0.1	41.6	Output	0	
Channel 8 clear value	0	BIT	0.1	41.7	Output	0	

- c. After the pulse input channel 1 count clear enable, the pulse frequency and pulse count value of channel 1 are 0, as shown below.

The screenshot shows the TwinCAT software interface. On the left is the Solution Explorer with a tree view of the project structure. On the right is a data table listing channel parameters.

Name	Online	Type	Size	>Address	In/Out	User ID	Linked to
Channel 1 frequency	0	UINT	2.0	41.0	Input	0	
Channel 1 count value	0	UDINT	4.0	43.0	Input	0	
Channel 2 frequency	0	UINT	2.0	47.0	Input	0	
Channel 2 count value	0	UDINT	4.0	49.0	Input	0	
Channel 3 frequency	0	UINT	2.0	53.0	Input	0	
Channel 3 count value	0	UDINT	4.0	55.0	Input	0	
Channel 4 frequency	0	UINT	2.0	59.0	Input	0	
Channel 4 count value	0	UDINT	4.0	61.0	Input	0	
Channel 5 frequency	0	UINT	2.0	65.0	Input	0	
Channel 5 count value	0	UDINT	4.0	67.0	Input	0	
Channel 6 frequency	0	UINT	2.0	71.0	Input	0	
Channel 6 count value	0	UDINT	4.0	73.0	Input	0	
Channel 7 frequency	0	UINT	2.0	77.0	Input	0	
Channel 7 count value	0	UDINT	4.0	79.0	Input	0	
Channel 8 frequency	0	UINT	2.0	83.0	Input	0	
Channel 8 count value	0	UDINT	4.0	85.0	Input	0	

## 6.2.2 Application in TIA Portal V17 software environment

### 1、 Preliminary

- **Hardware environment**
  - **Module Model XB6-PC80B**
  - **Power Module, PROFINET Coupler, End cover**  
This description takes the XB6-P2000H power supply, XB6-PN0002 coupler as an example
  - **One computer with pre-installed TIA Portal V17 software**
  - **Shielded cables for PROFINET**
  - **This description takes the connection of the XB6-P04A module as an example.**
  - **One Siemens PLC, this description takes Siemens S7-1200 CPU 1214C DC/DC/DC as an example**
  - **One switch power supply**
  - **Module mounting rails and rail fixings**
  - **Device Configuration File**  
Configuration file access: <https://www.solidotech.com/documents/configfile>
- **Hardware configuration and wiring**  
Follow "[4 Mounting and dismounting](#)" and "[5 Wiring](#)".

### 2、 New construction

- a. Open the TIA Portal V17 software and click Create New

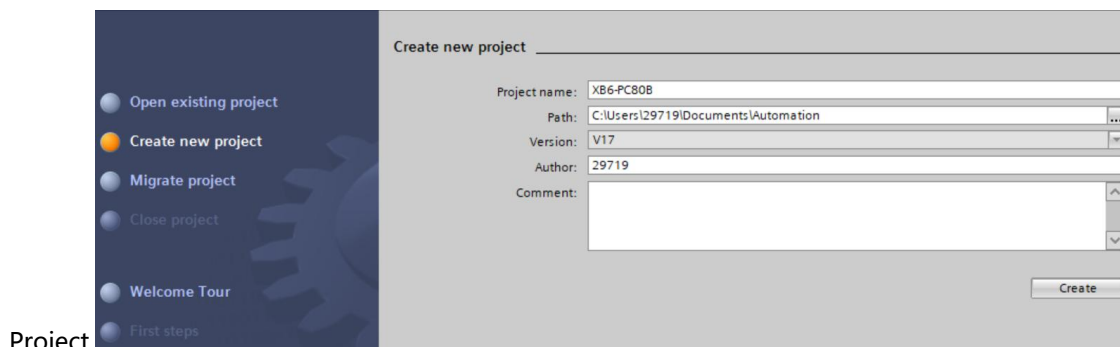

Project.

- ◆ Item name: customisable, can be left as default.
- ◆ Path: the project keeps the path, which can be left as default.
- ◆ Version: can be left as default.
- ◆ AUTHOR: The default may be maintained.
- ◆ Note: customisable, may not be filled in.

### 3. Adding a PLC controller

- a. Click Configure Devices, as shown in the following figure.

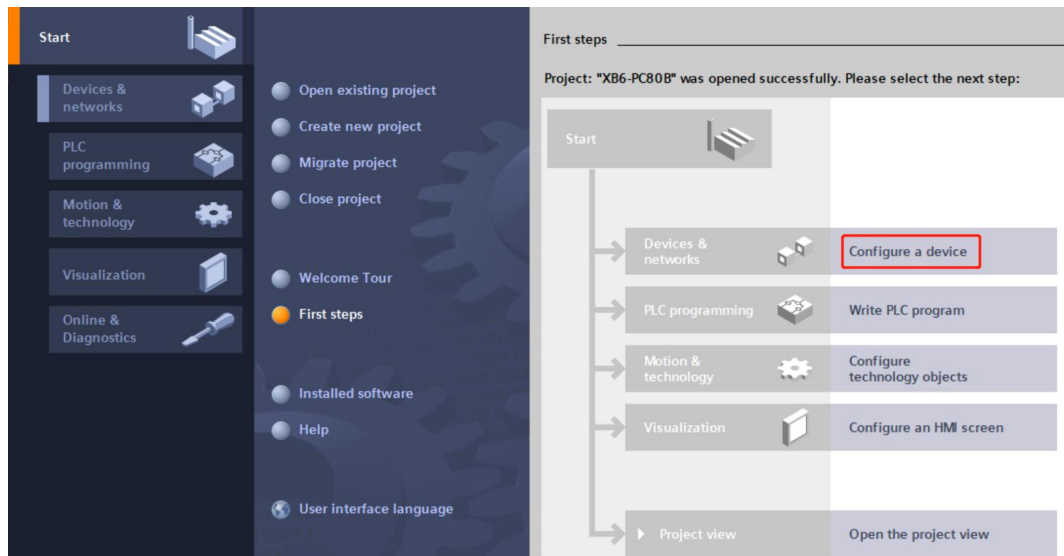

- b. Click "Add New Device", select the PLC model you are currently using, and click "Add", as shown in the following figure. After adding, you can see that the PLC has been added to the device navigation tree.

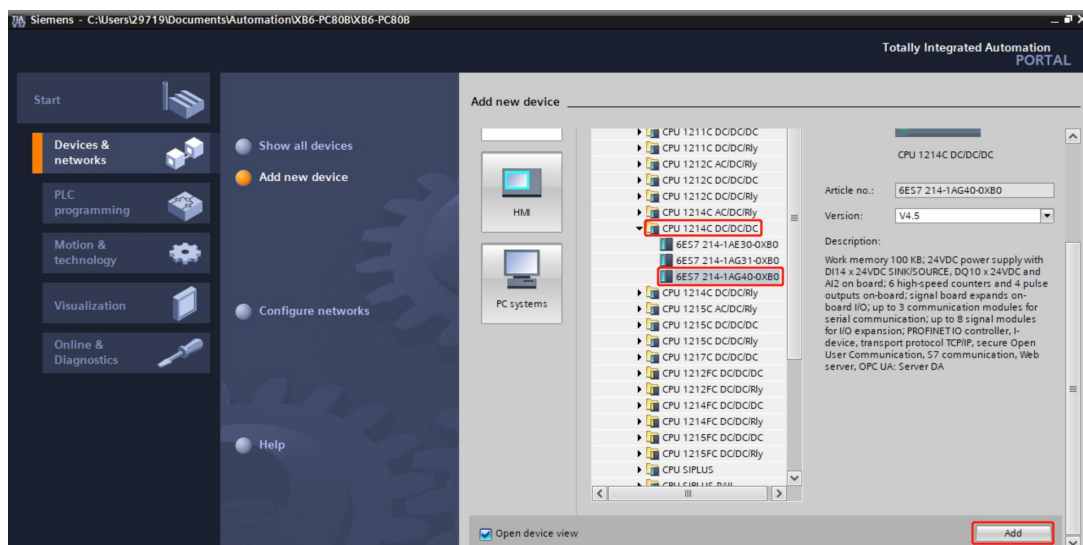

#### 4. Scanning connected devices

- a. Click "Online Access -> Update Accessible Devices" in the left navigation tree as shown below.

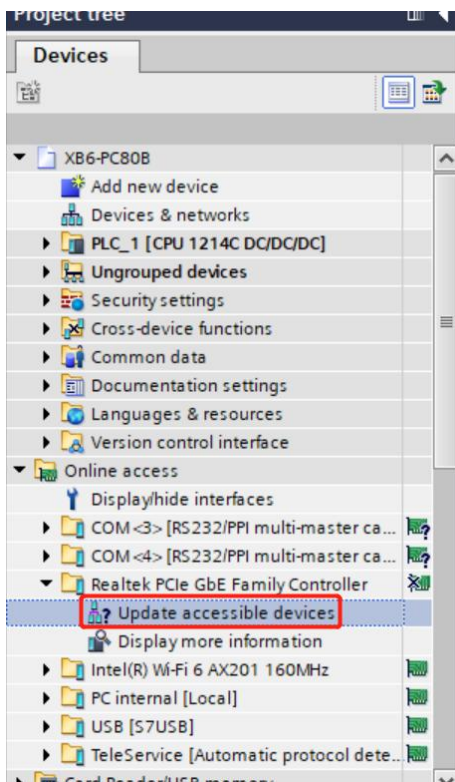

- b. When the update is complete, the connected slave devices are displayed, as shown in the following figure.

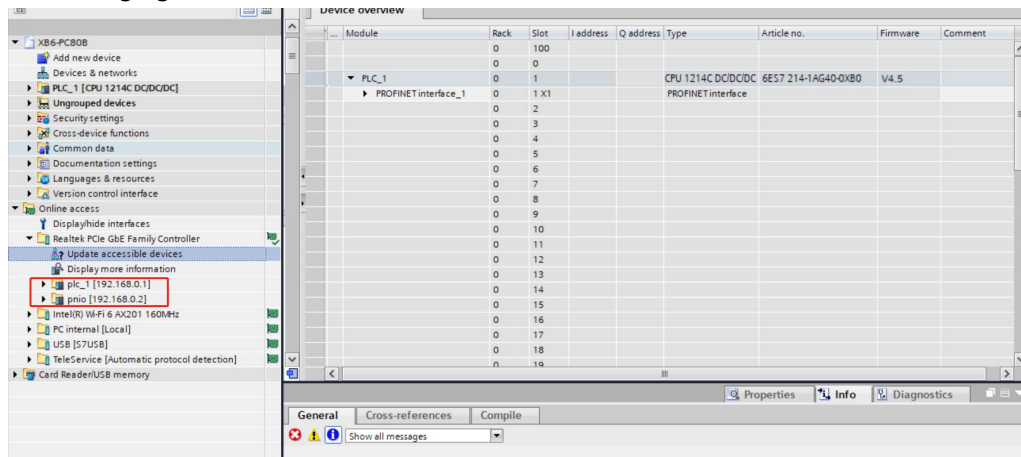

The IP address of the computer must be in the same network segment as the PLC, if not, modify the IP address of the computer and repeat the above steps.

## 5. Adding a GSD profile

- In the menu bar, select "Options -> Manage General Station Description File (GSDML) (D)".
- Click Source Path to select the file.
- Check if the status of the GSD file you want to add is "Not yet installed", click Install if it is not installed, or Cancel if it is already installed to skip the installation step.

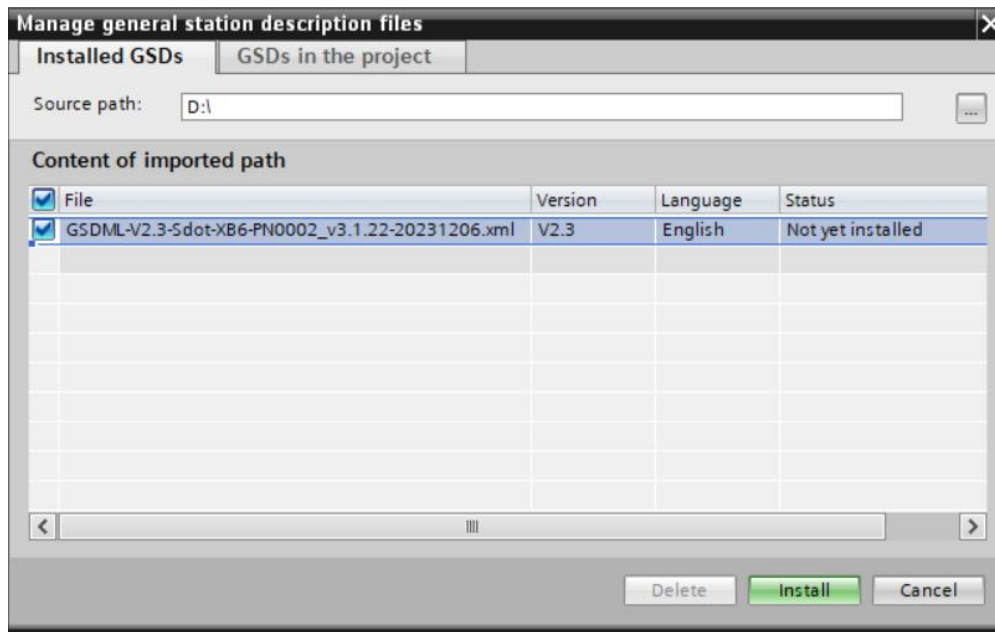

## 6. Adding Slave Devices

- Double-click on "Devices and Networks" in the left navigation bar.
- Click the "Hardware Catalogue" vertical button on the right, the catalogue will be displayed as shown below.

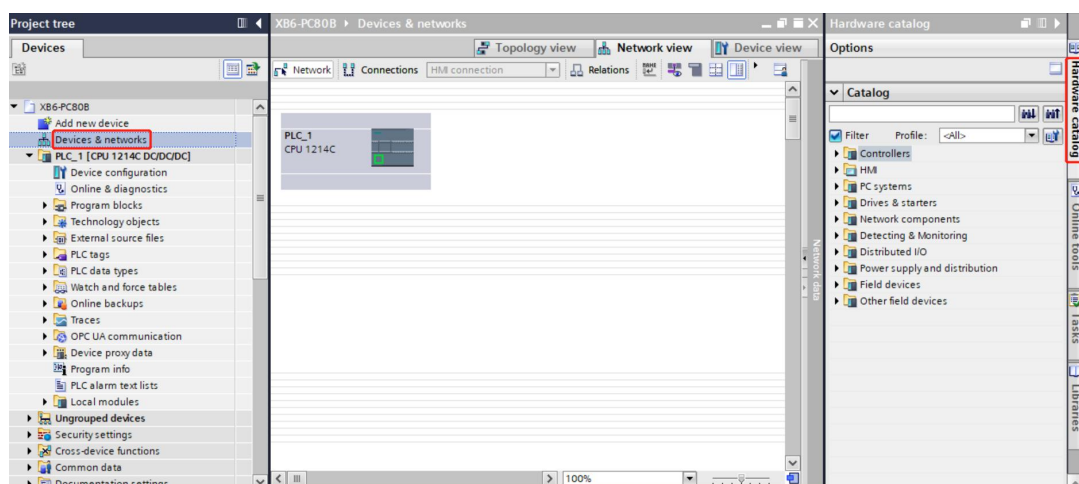

- Select "Other field devices -> PROFINET IO -> I/O -> Sdot -> X-Bus -> XB6-PN0002".
- Drag or double-click "XB6-PN0002" to "Network View" as shown below.

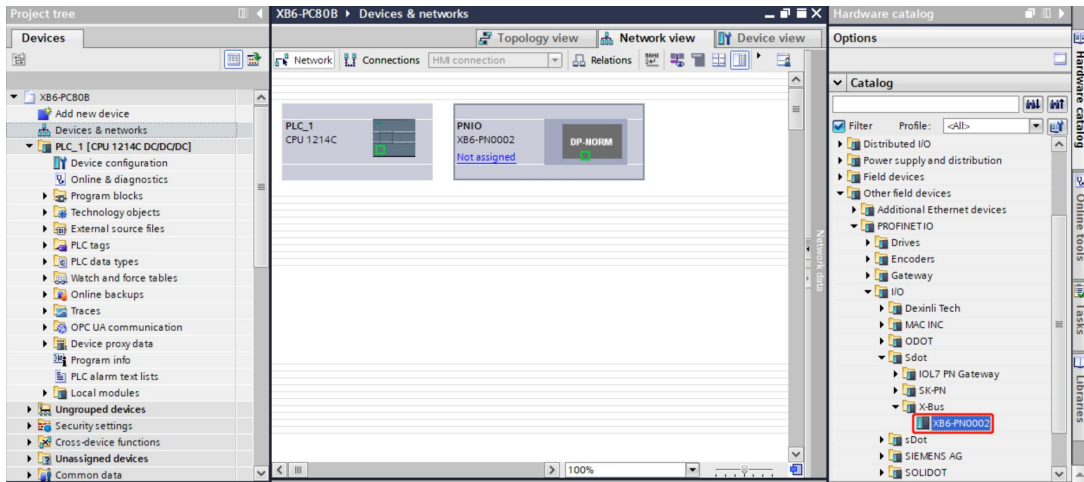

- e. Click "Unassigned (blue font)" on the slave device and select "PLC\_1.PROFINET Interface\_1" as shown below.

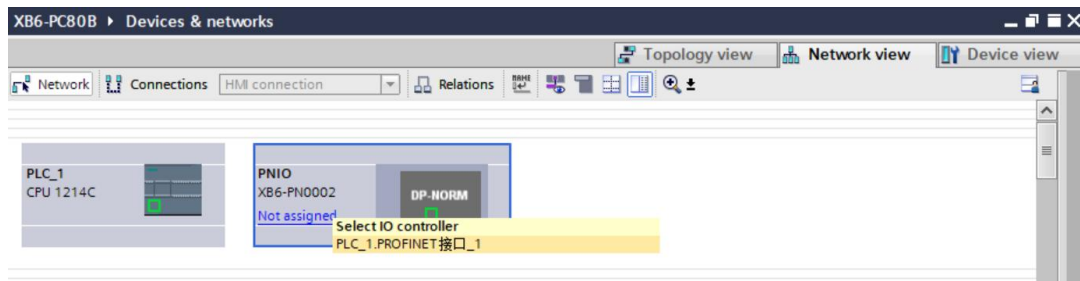

- f. When the connection is complete, it is shown below.

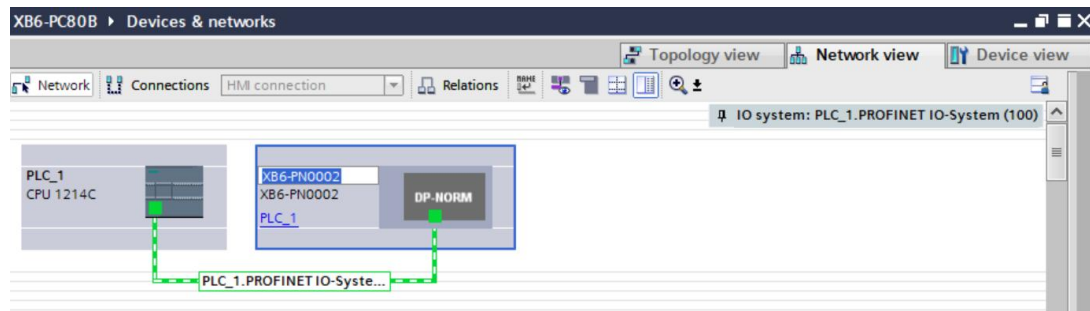

- g. Click the device name to rename the device, as shown in the following figure.

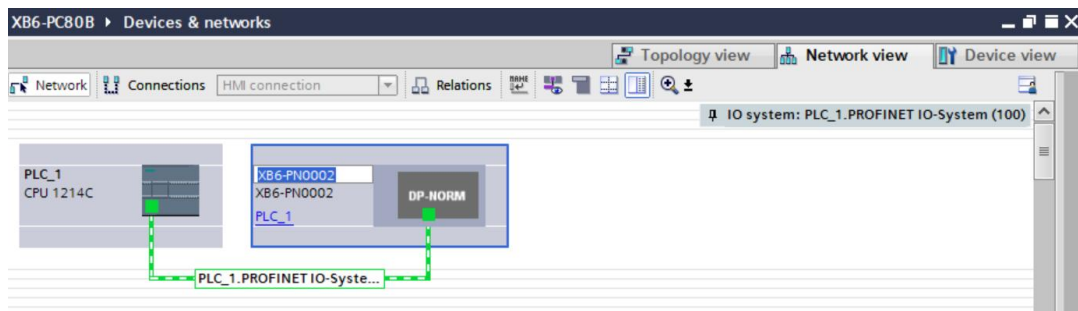

- h. Click on "Device View" to enter the device overview of the coupler, and under "Hardware Catalogue" on the right, add modules according to the actual topology (the order must be consistent with the actual topology, otherwise communication will not be successful), as shown in the following figure.

Module	Rack	Slot	I address	Q address	Type
XB6-PN0002	0	0			XB6-PN0002
PN-HO	0	0 X1			PNIO
XB6-PC80B_1	0	1	68...115	64	XB6-PC80B
XB6-P04A_1	0	2	2...49	2...53	XB6-P04A
	0	3			
	0	4			
	0	5			
	0	6			
	0	7			
	0	8			
	0	9			
	0	10			
	0	11			
	0	12			
	0	13			
	0	14			
	0	15			
	0	16			
	0	17			
	0	18			
	0	19			

## 7. Assign device name

- a. Switch to "Network View", right-click the connection line between PLC and coupler, and select "Assign Device Name" as shown in the following figure.

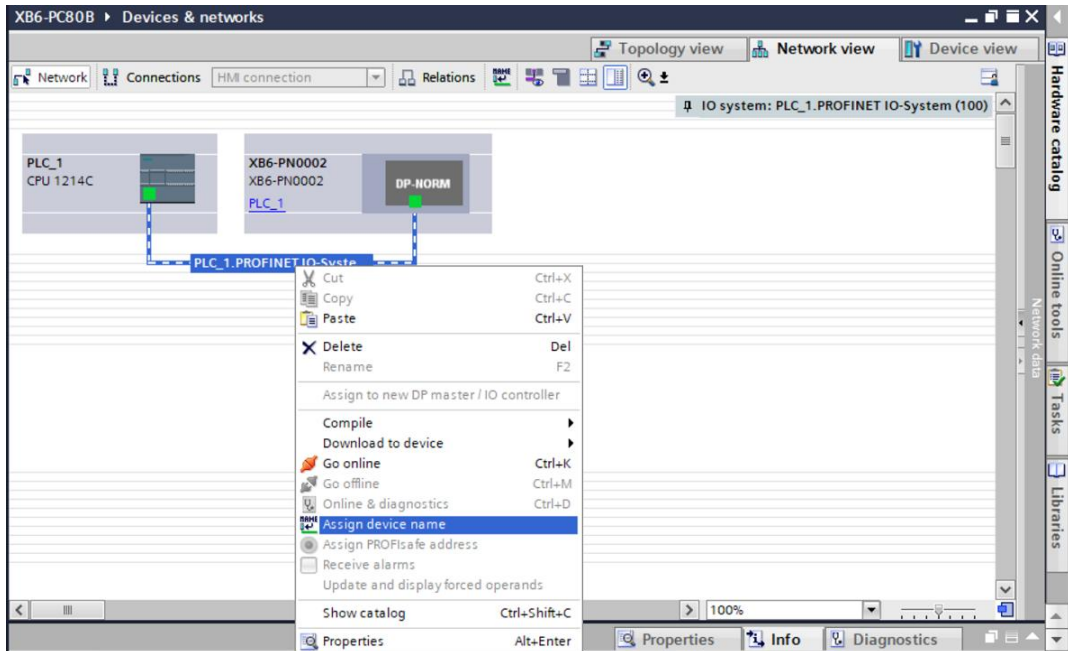

- b. The "Assign PROFINET Device Name" pop-up window appears as shown below.

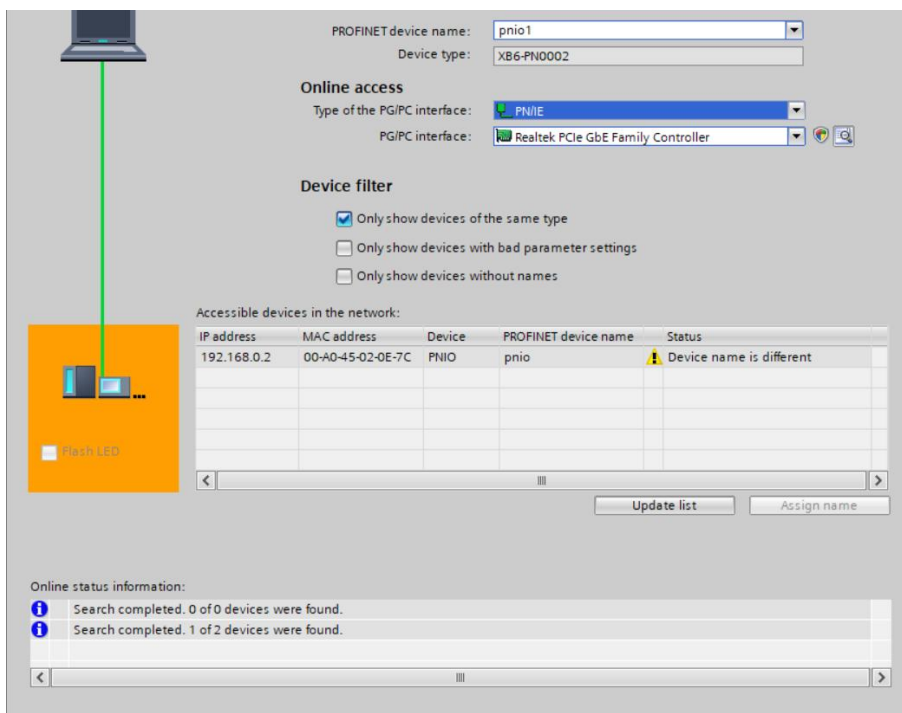

Check to see if the MAC address on the coupler silkscreen is the same as the MAC address of the assigned device name.

- ◆ PROFINET Device Name: The name set in "Assign IP address and device name to slave".
- ◆ Type of PG/PC interface: PN/IE.

- ◆ PG/PC interface: the actual network adapter used.
- c. Select the slave device in turn, click Update List, and click Assign Name. Check whether the status of the node is "OK" in "Accessible nodes in the network", as shown in the following figure.

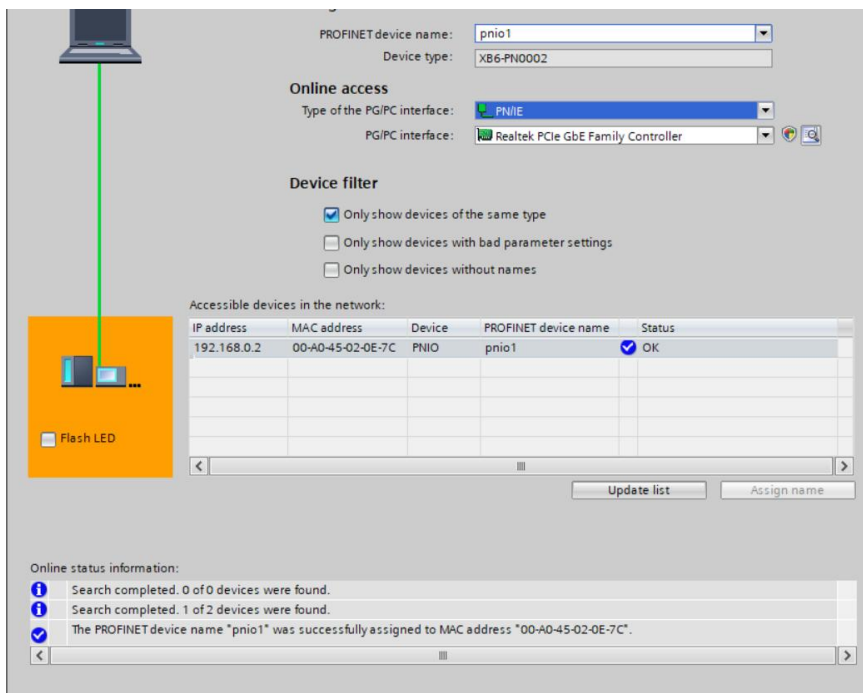

- d. Click Close.

## 8. Download Configuration Structure

- a. In Network View, select PLC.
- b. Click the  button in the menu bar to download the current configuration to the PLC.
- c. In the pop-up interface of "Extension Download to Device", the configuration is shown in the following figure.

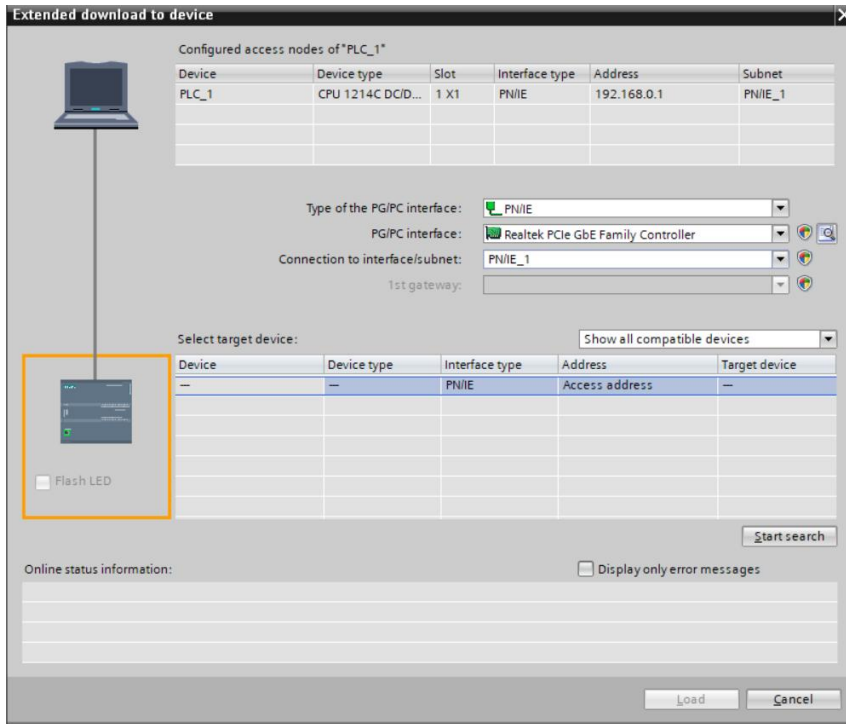

d. Click "Start Search" as shown below.

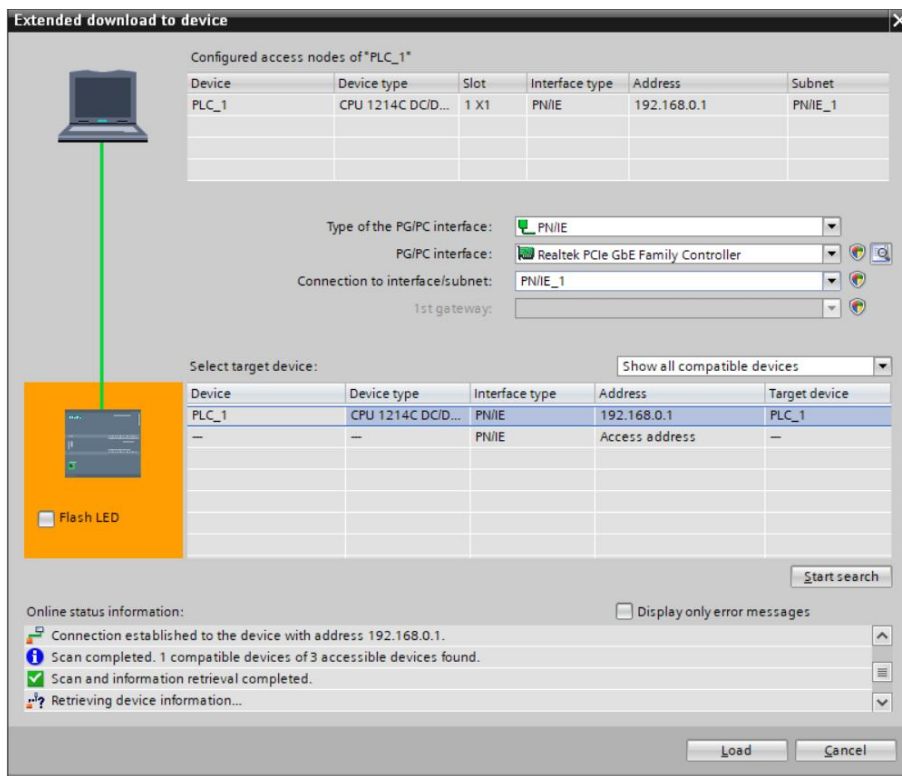

e. Click on "Download".

f. Select "Continue without synchronisation" as shown below.

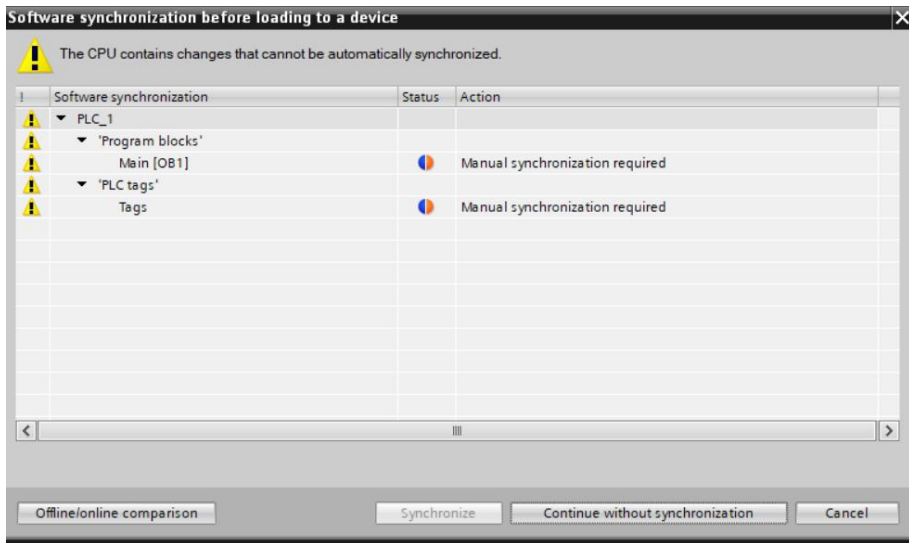

- g. Select "Stop All".

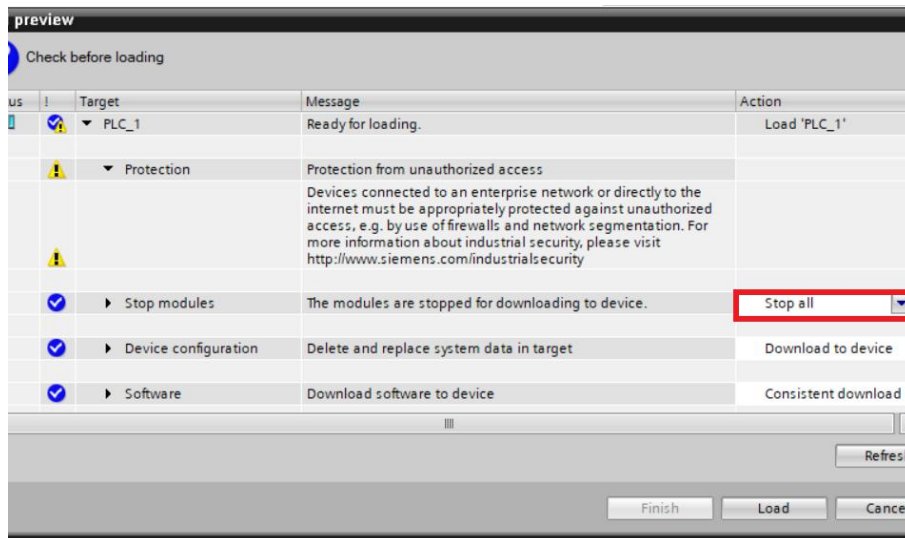

- h. Click Load.
- i. Click Finish.
- j. Power the unit back up.

## 9、 communication link



- a. Click the button, and then click the "Go Online" button, the icons are green, that is, the connection is successful, as shown in the figure below.

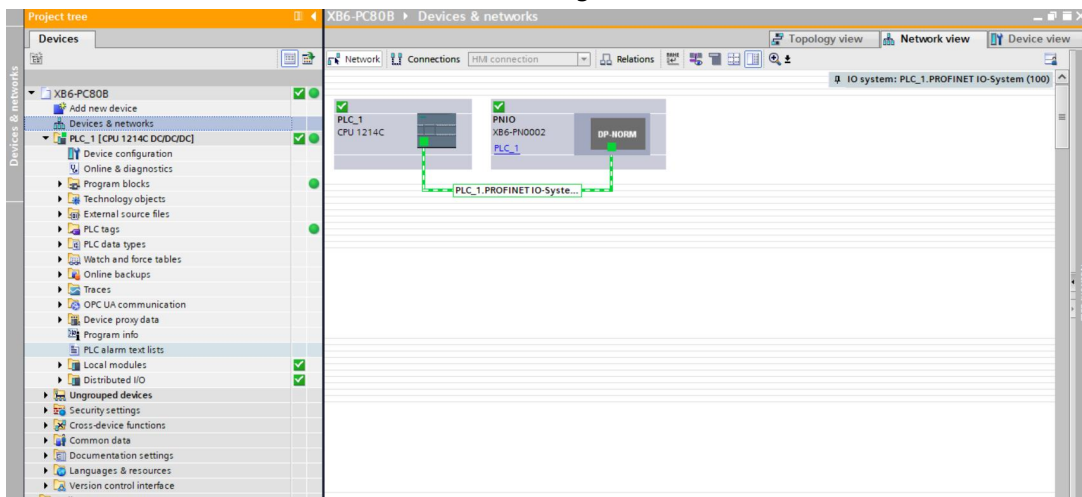

## 10、 Check the device indicator

XB6-P2000H: P lamp green is always on.

XB6-PN0002: P lamp green is always on, L lamp is always on, B lamp is not on, R lamp is always on.

XB6-PC80B module: P lamp is always on, R lamp is always on.

## 11、 Functional verification

- a. Expand the project navigation on the left side and select "Monitor and Force Meter" as shown below.

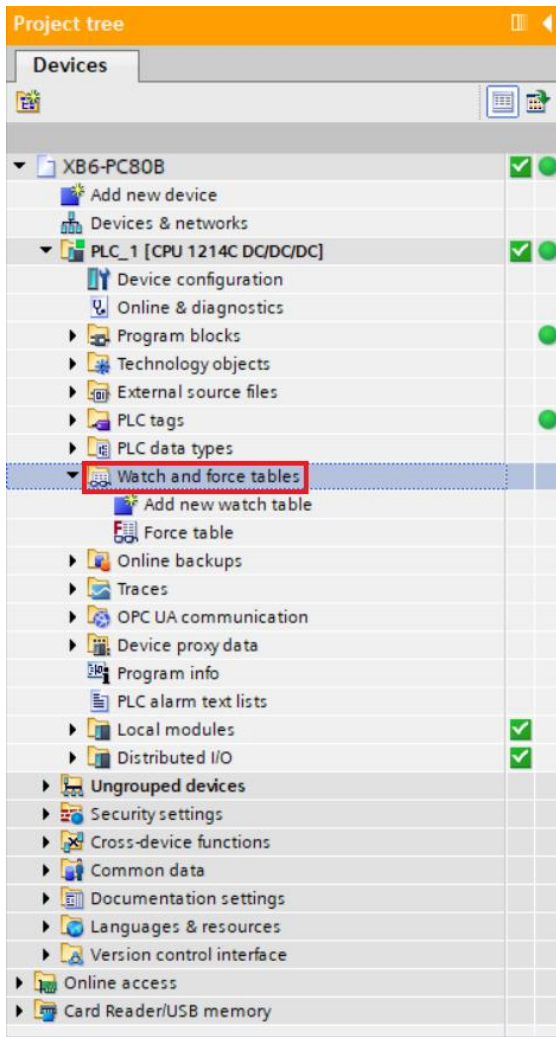

- b. Double-click "Add new monitoring table", the system adds a new monitoring table, as shown in the following figure.

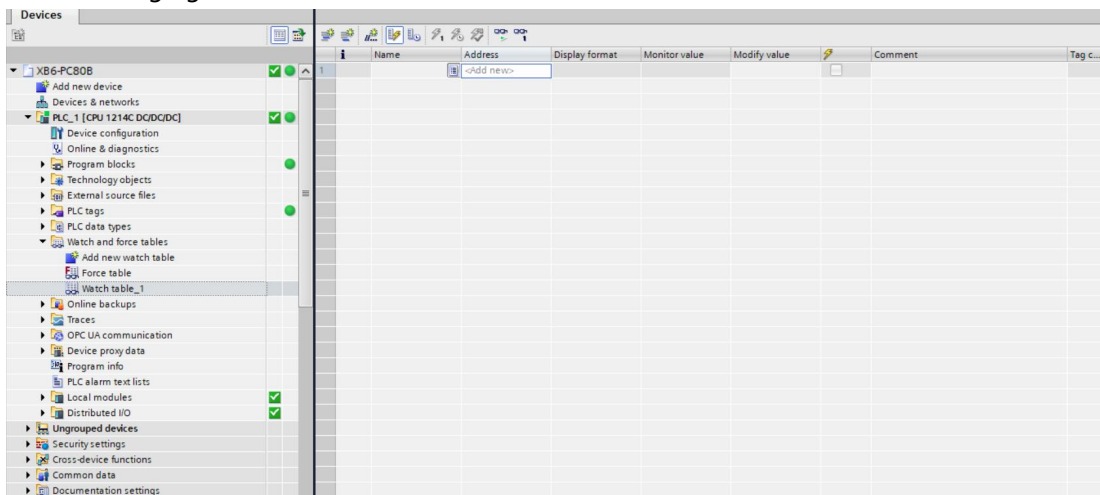

- c. Open the Device View and check the channel Q-address (channel address of the output signal) and I-address (channel address of the input signal) of the module XB6-PC80B in the device overview. For example, the "Q address" of XB6-PC80B module is 64, and the "I address" is 68 to 115, as shown in the following figure.

Module	Rack	Slot	I address	Q address	Type	Article number	Firmware
XB6-PN0002	0	0			XB6-PN0002	1234567	V10.00.00
PN-IO	0	0 X1			PNIO		
XB6-PC80B_1	0	1	68...115	64	XB6-PC80B		1.0
XB6-P04A_1	0	2	2...49	2...53	XB6-P04A		2.0
	0	3					
	0	4					

- d. Input the address, data type and comments in the Address cell of the monitoring table to facilitate monitoring. You can refer to the definition of upstream and downstream process data, enter the data items sequentially, press the Enter key, and then click the  button to monitor the data after all the fields are filled in.

**The correspondence between input and output data and addresses can be viewed in the table "XB6-PC80B Variable Address Calculation Tool.xlsx".**

- e. The module's uplink data is shown below in the monitoring table, which allows you to monitor the module's pulse frequency and pulse count value.

Name	Address	Display format	Monitor value	Modify v...	Comment
	%Q64.3	Bool	FALSE	<input type="checkbox"/>	Count Clear CH4
	%Q64.4	Bool	FALSE	<input type="checkbox"/>	Count Clear CH5
	%Q64.5	Bool	FALSE	<input type="checkbox"/>	Count Clear CH6
	%Q64.6	Bool	FALSE	<input type="checkbox"/>	Count Clear CH7
	%Q64.7	Bool	FALSE	<input type="checkbox"/>	Count Clear CH8
%IW68	DEC	0	<input type="checkbox"/>	<input type="checkbox"/>	Pulse Frequency CH1
%ID70	DEC	0	<input type="checkbox"/>	<input type="checkbox"/>	Pulse Count CH1
%IW74	DEC	0	<input type="checkbox"/>	<input type="checkbox"/>	Pulse Frequency CH2
%ID76	DEC	0	<input type="checkbox"/>	<input type="checkbox"/>	Pulse Count CH2
%IW80	DEC	0	<input type="checkbox"/>	<input type="checkbox"/>	Pulse Frequency CH3
%ID82	DEC	0	<input type="checkbox"/>	<input type="checkbox"/>	Pulse Count CH3
%IW86	DEC	0	<input type="checkbox"/>	<input type="checkbox"/>	Pulse Frequency CH4
%ID88	DEC	0	<input type="checkbox"/>	<input type="checkbox"/>	Pulse Count CH4
%IW92	DEC	0	<input type="checkbox"/>	<input type="checkbox"/>	Pulse Frequency CH5
%ID94	DEC	0	<input type="checkbox"/>	<input type="checkbox"/>	Pulse Count CH5
%IW98	DEC	0	<input type="checkbox"/>	<input type="checkbox"/>	Pulse Frequency CH6
%ID100	DEC	0	<input type="checkbox"/>	<input type="checkbox"/>	Pulse Count CH6
%IW104	DEC	0	<input type="checkbox"/>	<input type="checkbox"/>	Pulse Frequency CH7
%ID106	DEC	0	<input type="checkbox"/>	<input type="checkbox"/>	Pulse Count CH7
%IW110	DEC	0	<input type="checkbox"/>	<input type="checkbox"/>	Pulse Frequency CH8
%ID112	DEC	0	<input type="checkbox"/>	<input type="checkbox"/>	Pulse Count CH8

- f. The downstream data of the module is shown below in the monitoring table and is used to control the zeroing of the module's pulse data.

Name	Address	Display format	Monitor value	Modify v...	Comment
%Q64.0	%Q64.0	Bool	FALSE		Count Clear CH1
%Q64.1	%Q64.1	Bool	FALSE		Count Clear CH2
%Q64.2	%Q64.2	Bool	FALSE		Count Clear CH3
%Q64.3	%Q64.3	Bool	FALSE		Count Clear CH4
%Q64.4	%Q64.4	Bool	FALSE		Count Clear CH5
%Q64.5	%Q64.5	Bool	FALSE		Count Clear CH6
%Q64.6	%Q64.6	Bool	FALSE		Count Clear CH7
%Q64.7	%Q64.7	Bool	FALSE		Count Clear CH8
%IW68	%IW68	DEC	0		Pulse Frequency CH1
%ID70	%ID70	DEC	0		Pulse Count CH1
%IW74	%IW74	DEC	0		Pulse Frequency CH2
%ID76	%ID76	DEC	0		Pulse Count CH2
%IW80	%IW80	DEC	0		Pulse Frequency CH3
%ID82	%ID82	DEC	0		Pulse Count CH3
%IW86	%IW86	DEC	0		Pulse Frequency CH4
%ID88	%ID88	DEC	0		Pulse Count CH4
%IW92	%IW92	DEC	0		Pulse Frequency CH5
%ID94	%ID94	DEC	0		Pulse Count CH5
%IW98	%IW98	DEC	0		Pulse Frequency CH6
%ID100	%ID100	DEC	0		Pulse Count CH6
%IW104	%IW104	DEC	0		Pulse Frequency CH7
%ID106	%ID106	DEC	0		Pulse Count CH7
%IW110	%IW110	DEC	0		Pulse Frequency CH8
%ID112	%ID112	DEC	0		Pulse Count CH8

### Examples of module functions

#### ◆ Pulse input channel 1 data monitoring and clearing

- a. When channel 1 inputs 10000 pulses with a frequency of 500Hz, the module's uplink data pulse frequency and pulse count value, as shown below. When the pulse starts to be sent, the pulse count value continues to accumulate, and the pulse frequency is monitored in real time. When sending is completed, the pulse count value accumulates to 10000; when there is no pulse input, the frequency is 0.

Name	Address	Display format	Monitor value	Modify v...	Comment
%Q64.3	%Q64.3	Bool	FALSE		Count Clear CH4
%Q64.4	%Q64.4	Bool	FALSE		Count Clear CH5
%Q64.5	%Q64.5	Bool	FALSE		Count Clear CH6
%Q64.6	%Q64.6	Bool	FALSE		Count Clear CH7
%Q64.7	%Q64.7	Bool	FALSE		Count Clear CH8
%IW68	%IW68	DEC	500		Pulse Frequency CH1
%ID70	%ID70	DEC	10000		Pulse Count CH1
%IW74	%IW74	DEC	0		Pulse Frequency CH2
%ID76	%ID76	DEC	0		Pulse Count CH2
%IW80	%IW80	DEC	0		Pulse Frequency CH3
%ID82	%ID82	DEC	0		Pulse Count CH3
%IW86	%IW86	DEC	0		Pulse Frequency CH4
%ID88	%ID88	DEC	0		Pulse Count CH4
%IW92	%IW92	DEC	0		Pulse Frequency CH5
%ID94	%ID94	DEC	0		Pulse Count CH5
%IW98	%IW98	DEC	0		Pulse Frequency CH6
%ID100	%ID100	DEC	0		Pulse Count CH6
%IW104	%IW104	DEC	0		Pulse Frequency CH7
%ID106	%ID106	DEC	0		Pulse Count CH7
%IW110	%IW110	DEC	0		Pulse Frequency CH8
%ID112	%ID112	DEC	0		Pulse Count CH8

- b. Pulse input channel 1 count clear enable, the pulse frequency and pulse count value of channel 1 are 0, as shown below.

Name	Address	Display format	Monitor value	Modify v...	Comment
	%Q64.0	Bool	TRUE	TRUE	Count Clear CH1
	%Q64.1	Bool	FALSE		Count Clear CH2
	%Q64.2	Bool	FALSE		Count Clear CH3
	%Q64.3	Bool	FALSE		Count Clear CH4
	%Q64.4	Bool	FALSE		Count Clear CH5
	%Q64.5	Bool	FALSE		Count Clear CH6
	%Q64.6	Bool	FALSE		Count Clear CH7
	%Q64.7	Bool	FALSE		Count Clear CH8
	%IW68	DEC	0		Pulse Frequency CH1
	%ID70	DEC	0		Pulse Count CH1
	%IW74	DEC	0		Pulse Frequency CH2
	%ID76	DEC	0		Pulse Count CH2
	%IW80	DEC	0		Pulse Frequency CH3
	%ID82	DEC	0		Pulse Count CH3
	%IW86	DEC	0		Pulse Frequency CH4
	%ID88	DEC	0		Pulse Count CH4
	%IW92	DEC	0		Pulse Frequency CH5
	%ID94	DEC	0		Pulse Count CH5
	%IW98	DEC	0		Pulse Frequency CH6
	%ID100	DEC	0		Pulse Count CH6
	%IW104	DEC	0		Pulse Frequency CH7
	%ID106	DEC	0		Pulse Count CH7
	%IW110	DEC	0		Pulse Frequency CH8